

An Experimental Approach to Formulate an Approximate Generalized Experimental Data Based Model for Wood Chipper Cutter Energized By HPFM

Mr. Vivek M Sonde, Dr. P. N. Belkhode, Mr. S. N. Waghmare and Mr. S. K. Undirwade

Abstract: Wood is an important source to human beings for many years & it is especially an integral part of the cultural, social and economic traditions of many societies. Wood chips are pulped to make paper. Most of the papers are made from softwood trees such as fir, pine and arhar. Wood is one of the most important building materials. The machine consists of human powered flywheel motor as an energy source. The hpfm comprises of subsystems like human powered process unit, appropriate clutch and transmission and a process unit. Energy unit consists of bicycle-drive mechanism with speed increasing gearing, appropriate clutch transmission and a flywheel. The operator drives the bicycle by pedaling the mechanism while clutch is in disengage position. The hpfm is energy source. This energy source energizes the process unit through clutch and transmission. The flywheel is accelerate and energies which stores some energy inside it. When the pedaling is stopped, clutch is engaged and stores energy in the flywheel is transferred to the process unit input shaft by means of clutch. The process unit is wood chipper unit which comprises of upper & lower in feed & feed out rollers, counter knife, adjusting knobs, helical spur gear train, foundation frame and knuckle and pipe joint.

Keywords:- Wood, Wood Chips, processing machinery, Flywheel, HPFM

1 Introduction & Overview

Wood is an important source to human beings for many years & it is especially an integral part of the cultural, social and economic traditions of

many societies. Vidarbha region is forest intensive area where wood is regular & easily available product. Wood chips are pulped to make paper. Most of the papers are made from softwood trees such as fir, pine and arhar. Paper has been important to write and print on. Without it we would not have books, magazines or newspapers. Wood is one of the most important building materials. The machine consists of human powered flywheel motor as an energy source. The human powered flywheel motor comprises of subsystems like human powered process unit, appropriate clutch and transmission and a process unit. Energy unit consists of bicycle-drive mechanism with speed increasing gearing, appropriate clutch transmission and a flywheel.

The operator pumps energy to the flywheel at a convenient input power level. After enough energy is stored, pedaling is stopped and the energy in the flywheel is made available to the process unit by engaging the clutch.

2 Aim, Objective and Scope

Due to rapid industrialization coupled with limitations on additional power generation and non-availability of power in the interior area, India is facing problems of power shortage. In this context the sources of energy is human power operated systems which are considered to be one of the form of non-conventional energy sources. Thus in this aspect, this work aims at developing approximate generalized experimental data based model for wood chipper cutter by means of human powered flywheel motor. The machine so developed is expected to have better quality of product of wood chips. At the same time the processing will be more

efficient and more energy efficient. A new human power operated machine or unit will be fabricated based on improved design and will be tested for the performance.

This research work is selected with following objectives and reasons: Cutting of trees is major responsible factor for global warming, the increasing issues of farmer suicide in rural areas, unemployment & non profitable production. The major objectives are possibility of formulation of mathematical model for assessment of wood chipping properties and development of such model and possibility of formulation of Artificial Neural Network model for assessment of wood chipping properties and development of such model.

Vidarbha region is forest intensive area having large part of it covered with dense forest. Wood is regular product of the local forest. Large varieties of local industries utilize wood as a raw material for manufacturing goods which are mainly value added products. Large numbers of these products are exported. So it is the source of foreign exchange for the country. At the same time it is a labor intensive industry, having potential to provide gainful employment to large section of rural and forest population which is also in the interest of economical development. The main theme involved in this work is to formulate approximate generalized experimental data based model for wood chipper cutter using human powered flywheel motor in a single unit.

This machine is very useful in rural areas because wood articles have very high demand in rural market. So, they can start their own business of making wood chips by purchasing this machine. As it is operated by human powered flywheel, it does not require electric power. The unit operating by means of electricity has limited applications in the rural area. In remote and interior places where there is no facility of electricity as well as in urban areas, while in the duration of load shading or during electrical power-off timings, this type of human power operated unit will have very extensive

utility.

In the view of forgoing it is obvious that one will have to decide what should be the minimum processing torque and cutting force required and energy to be supplied to the system for getting appropriate sizes of processed wood in minimum time. By knowing this, one can establish wood machining properties. This would be possible if one can have a quantitative relationship amongst various dependent and independent variables of the system. This relationship would be known as the mathematical model of this wood chipper cutting operation. It is well known that such a model for the wood chipping cannot be formulated applying logic. The only option with which one is left is to formulate an experimental data based model [1]. Hence in this investigation, it is decided to formulate such an experimental data based model. In this approach all the independent variable will be varied over a widest possible range, a response data will be collected and an analytical relationship will be established. Once such a relationship is established then the technique of optimization [2] will be applied to deduce the values of independent variables at which the necessary responses will be minimized or maximized. Hence in this research, it is decided to make conformity about functional feasibility and economic viability of human powered unit for wood chipper cutter machine. This aims to establish the energized experimental model by means of human powered flywheel motor for chips cutting from wood

3 Working of the System

The operator drives the bicycle by pedaling the mechanism while clutch is in disengage position. The human power operated flywheel motor is energy source. This energy source energizes the process unit through clutch and transmission. The flywheel is accelerate and energies which stores some energy inside it. When the pedaling is stop, clutch is engage and store energy in the flywheel is transferred to the process unit input shaft by

means of clutch. The process unit is wood chipper unit which comprises of upper & lower in feed & feed out rollers, counter knife, adjusting knobs, helical spur gear train,

foundation frame and knuckle and pipe joint. [3, 4-7]

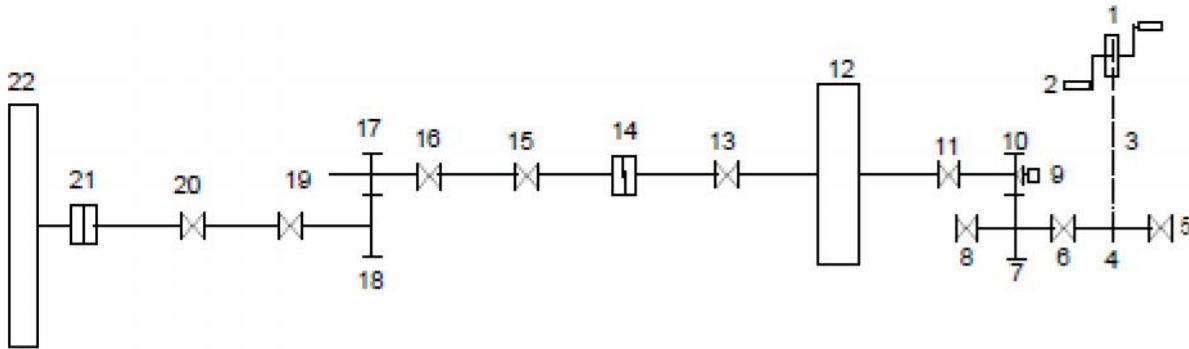

Figure1: Schematic Arrangement of human powered Wood Chipper Cutter Unit 1-Chain Sprocket, 2- Pedal, 3- Chain, 4- Freewheel, 5 & 6- Bearing for bicycle, 7- Gear I, 8- Bearing, 9- Tachogenerator for flywheel shaft, 10- Pinion I, 11- Bearing for flywheel shaft, 12- Flywheel, 13- Bearing for flywheel, 14- Two jaw Clutch, 15 & 16- Bearing of intermediate shaft, 17- Pinion II, 18- Gear-II, 19 & 20- Bearing for process unit shaft, 21- Coupling, 22- Process Unit.

When the input shaft is rotated by means of energy transferred by the flywheel with the help of clutch, the pulley keyed to the input shaft starts to rotate due to which the rollers are driven by knuckle and pipe joint through helical spur gear train which is keyed to shaft. The shafts of the rollers are supported in brass bush bearings which are fixed in spring loaded housing to accommodate any size of wood. The wood or crop stem is fed and guided through the feeder which is fixed before pull-in arbor type rollers at the front end of process unit i.e. chipper cutting unit. When the wood is fed through the feeder and pull-in rollers of chipper cutting unit, it passes

through rotating pull-in rollers and due to the force given by pull-in rollers, that wood passes through the rotating push-out rollers and when this wood comes out of push-out rollers, it strikes to chipper cutter which is fitted just after push-out rollers. By positioning the cutter in downward direction, the chips are cut from wood. The thickness of chip is adjusted by adjusting the position of wood by moving the chipper cutter up and down by means of studs fixed to the cutter frame. For continuous contact between the wood and cutter, a spring tension of the springs fitted over the bearing housing is adjusted by tightening and loosening the adjusting knobs. This helps in adjusting any size of wood chips [8].

through rotating pull-in rollers and due to the force given by pull-in rollers, that wood passes through the rotating push-out rollers and when this wood comes out of push-out rollers, it strikes to chipper cutter which is fitted just after push-out rollers. By positioning the cutter in downward direction, the chips are cut from wood. The thickness of chip is adjusted by adjusting the position of wood by moving the chipper cutter up and down by means of studs fixed to the cutter frame. For continuous contact between the wood and cutter, a spring tension of the springs fitted over the bearing housing is adjusted by tightening and loosening the adjusting knobs. This helps in adjusting any size of wood chips [8].

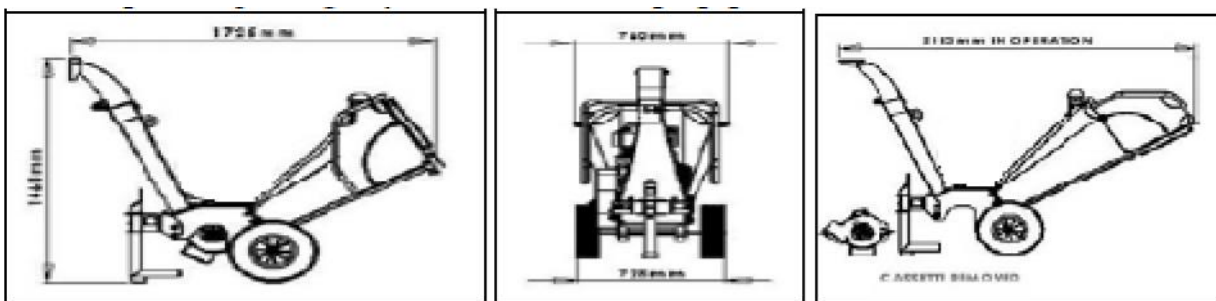

Figure 2: Main proposed process unit of wood chipper cutter machine showing the inlet and outlet manifold from different views.

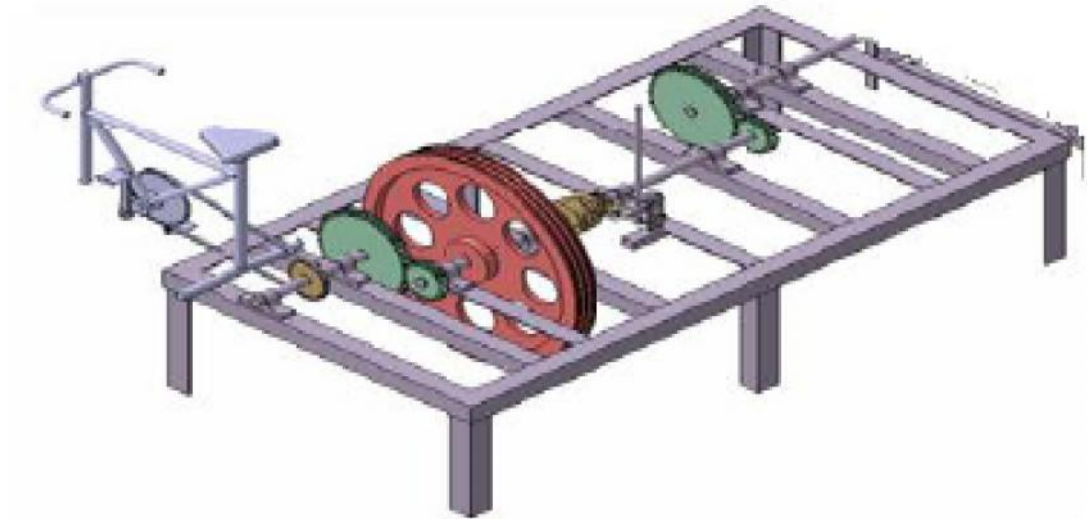

Figure 3: Bicycle mechanism with flywheel as energy unit with mechanical power transmission from input to the output by

means of mechanical component like chains, shaft, gears, flywheel & coupling.

4. Identification of Variables:

The term variables are used in a very general sense to apply any physical quantity that undergoes change [8]. The various physical quantities or parameters involved in the process of wood chipping will be identified. The variables affecting the effectiveness of the phenomenon under consideration might be speed,

cutter dimensions, cross section of material to be processed, elasticity of material, cutting angle, feed and power. The dependent or the response variables in this case are :-

- a) Processing Torque**
- b) Processing Energy and**
- c) Processing Time**

4.1 Dimensional Equations:

The dimensional equations will be established in reduced or compact mode in order to make the complete experimentation process less time taking having generation of optimum data.

Buckingham π Theorem will be used for dimensional analysis. No of variables consider for dimensional analysis as mentioned in Table 1. Table 1: Variables related to Wood Chipping Operation

Sr. No	Variables	Symbols	Fundamental Equation	Dependent / Independent
1	Processing Torque	T_p	ML^3T^{-2}	Dependent
2	Processing Energy	E_p	ML^2T^{-2}	Dependent
3	Processing Time	t_p	T	Dependent
4	Mass of the material	Mm	N	Independent
5	Diameter of the cutter	Dc	L	Independent
6	Thickness of cutter	tc	L	Independent
7	Length of the cutter	Lc	L	Independent
8	Speed of the cutter	Nc	T^{-1}	Independent
9	Modules of elasticity of Material	Em	$ML^{-1}T^{-2}$	Independent
10	Modules of elasticity of Cutter	Ec	$ML^{-1}T^{-2}$	Independent
11	Cutting angle	Φ		Independent
12	Feed of the material	Fm	LT^{-1}	Independent

The Buckingham's II- Theorem is used for the dimensional analysis of proposed machine after identifying the dependant and independent variables. The process of dimensional analysis is followed step by step as explained below: The processing torque, T_p is function of Mass of wood (Mm), Diameter of Cutter (Dc), Length of

the cutter (Lc), Thickness of the cutter (Tc), Speed of the cutter (Nc), Modulus of elasticity of wood (Em), Modulus of elasticity of cutter (Ec), Cutting angle of cutter (Φ c). Thus processing torque, T_p is dependent variable and others are independent variables.

T_p = Function of (Mm, Dc, tc, Lc, Nc, Φ , Fm, Em, Ec)

E_p = Function of (Mm, Dc, tc, Lc, Nc, Φ , Fm, Em, Ec)

t_p = Function of (Mm, Dc, tc, Lc, Nc, Φ , Fm, Em, Ec)

Considering mass of the material (Mm) Speed of the Cutter (Nc) & Diameter of the cutter (Dc) as the repeating variables we get the π Equations as:

$$1) \quad \Pi_1 = (Mm)^{a_1}, (Nc)^{b_1}, (Dc)^{c_1}, (Tp) \quad \text{----- (1)}$$

$$\Pi_1 = (M)^{a_1}, (T^{-1})^{b_1}, (L)^{c_1}, (ML^2T^{-2})$$

$$M^0L^0T^0 = (M)^{a_1}, (T^{-1})^{b_1}, (L)^{c_1}, (ML^2T^{-2})$$

Power of M = 0, 0 = a ₁ + 1 a ₁ = -1	Power of L = 0, 0 = c ₁ + 2 c ₁ = -2	Power of T = 0, 0 = -b ₁ - 2 b ₁ = -2
--	--	---

Putting values of a₁, b₁, and c₁ in equation (1)

$$\Pi_1 = Mm^{-1}, Nc^{-2}, Dc^{-2}, Tp$$

$$\Pi_1 = \frac{Tp}{Mm, Nc^2, Dc^2}$$

$$2) \quad \Pi_2 = (Mm)^{a_2}, (Nc)^{b_2}, (Dc)^{c_2}, (tc) \quad \text{----- (2)}$$

$$\Pi_2 = (M)^{a_2}, (T^{-1})^{b_2}, (L)^{c_2}, L$$

$$M^0L^0T^0 = (M)^{a_2}, (T^{-1})^{b_2}, (L)^{c_2}, L$$

Power of M = 0 0 = a ₂ a ₂ = 0	Power of L = 0 0 = c ₂ + 1 c ₂ = -1	Power of T = 0 0 = -b ₂ b ₂ = 0
--	---	---

Putting values of a₂, b₂, and c₂ in equation (2)

$$\Pi_2 = Mm^0, Nc^0, Dc^{-1}, tc$$

$$\Pi_2 = \frac{tc}{Dc}$$

$$3) \quad \Pi_3 = (Mm)^{a_3}, (Nc)^{b_3}, (Dc)^{c_3}, (Lc) \quad \text{----- (3)}$$

$$\Pi_3 = (M)^{a_3}, (T^{-1})^{b_3}, (L)^{c_3}, L$$

$$M^0L^0T^0 = (M)^{a_3}, (T^{-1})^{b_3}, (L)^{c_3}, L$$

Power of M = 0 0 = a ₃ a ₃ = 0	Power of L = 0 0 = c ₃ + 1 c ₃ = -1	Power of T = 0 0 = -b ₃ b ₃ = 0
--	---	---

Putting values of a₃, b₃, and c₃ in equation (3)

$$\Pi_3 = Mm^0, Nc^0, Dc^{-1}, L$$

$$\Pi_3 = \frac{L}{Dc}$$

$$\Pi_4 = 0$$

$$5) \quad \Pi_5 = (Mm)^{a_5}, (Nc)^{b_5}, (Dc)^{c_5}, (Fm) \quad \text{----- (4)}$$

$$\Pi_5 = (M)^{a_5}, (T^{-1})^{b_5}, (L)^{c_5}, LT^{-1}$$

$$M^0L^0T^0 = (M)^{a_5}, (T^{-1})^{b_5}, (L)^{c_5}, LT^{-1}$$

Power of M = 0 0 = a ₅ a ₅ = 0	Power of L = 0 0 = c ₅ + 1 c ₅ = -1	Power of T = 0 0 = -b ₅ - 1 b ₅ = -1
--	---	--

Putting values of a₅, b₅, and c₅ in equation (4)

$$\Pi_5 = (Mm)^0, (Nc)^{-1}, (Dc)^{-1}, (Fm)$$

$$\Pi_5 = \frac{Fm}{Nc, Dc}$$

$$6) \quad \Pi_6 = (Mm)^{a_6}, (Nc)^{b_6}, (Dc)^{c_6}, (Em) \quad \text{----- (5)}$$

$$\Pi_6 = (M)^{a_6}, (T^{-1})^{b_6}, (L)^{c_6}, ML^{-1}T^{-2}$$

$$M^0L^0T^0 = (M)^{a_6}, (T^{-1})^{b_6}, (L)^{c_6}, ML^{-1}T^{-2}$$

Power of M = 0 0 = a ₆ + 1 a ₆ = -1	Power of L = 0 0 = c ₆ - 1 c ₆ = 1	Power of T = 0 0 = -b ₆ - 2 b ₆ = -2
---	--	--

Putting values of a₆, b₆, and c₆ in equation (5)

$$\Pi_6 = (Mm)^{-1}, (Nc)^{-2}, (Dc)^1, (Em)$$

$$\Pi_6 = \frac{Em \cdot Dc}{Mm \cdot Nc^2}$$

$$7) \quad \Pi_7 = (Mm)^{a_7}, (Nc)^{b_7}, (Dc)^{c_7}, (Ec) \quad \text{----- (6)}$$

$$\Pi_7 = (M)^{a_7}, (T^{-1})^{b_7}, (L)^{c_7}, ML^{-1}T^{-2}$$

$$M^0L^0T^0 = (M)^{a_7}, (T^{-1})^{b_7}, (L)^{c_7}, ML^{-1}T^{-2}$$

Power of M = 0 0 = a ₇ + 1 a ₇ = -1	Power of L = 0 0 = c ₇ - 1 c ₇ = 1	Power of T = 0 0 = -b ₇ - 2 b ₇ = -2
---	--	--

Putting values of a₇, b₇, and c₇ in equation (6) we get

$$\Pi_7 = (Mm)^{-1}, (Nc)^{-2}, (Dc)^1, (Ec)$$

$$\Pi_7 = \frac{Ec \cdot Dc}{Mm \cdot Nc^2}$$

T_p = f (Mm, Dc, tc, Lc, Nc, Ø, Fm, Em, Ec)

T_p = f (Π₁, Π₂, Π₃, Π₄, Π₅, Π₆, Π₇)

Replacing the values of all the Π terms in above all 6 equations we get T_p as

$$T_P = \left[\left(\frac{T_p}{MmNc^2Dc^2} \frac{tc}{Dc} \frac{L}{Dc} \ominus \frac{Fm}{NcDc} \frac{EmDc}{MmNc^2} \frac{EcDc}{MmNc^2} \right) \right]$$

$$T_P = O \left[\left(\frac{1}{MmNc^2Dc^2} \frac{tc}{Dc} \frac{L}{Dc} \frac{Fm}{NcDc} \frac{EmDc}{MmNc^2} \frac{EcDc}{MmNc^2} \right) \right]$$

Dimensional Equation for Processing Energy (E_p)

E_p = f (Mm, Dc, tc, Lc, Nc, Ø, Fm, Em, Ec)

E_p = f (Π₁, Π₂, Π₃, Π₄, Π₅, Π₆, Π₇)

$$1) \quad \Pi_1 = (Mm)^{a_1}, (Nc)^{b_1}, (Dc)^{c_1}, (Ep) \quad \text{----- (7)}$$

$$\Pi_1 = (M)^{a_1}, (T^{-1})^{b_1}, (L)^{c_1}, (ML^2T^{-2})$$

$$M^0L^0T^0 = (M)^{a_1}, (T^{-1})^{b_1}, (L)^{c_1}, (ML^2T^{-2})$$

Power of M = 0, 0 = a ₁ + 1 a ₁ = -1	Power of L = 0, 0 = c ₁ + 2 c ₁ = -2	Power of T = 0, 0 = -b ₁ - 2 b ₁ = -2
--	--	---

Putting values of a₁, b₁, and c₁ in equation (7)

$$\Pi_1 = Mm^{-1}, Nc^{-2}, Dc^{-2}, Ep$$

$$\Pi_1 = \frac{Ep}{Mm \cdot Nc^2 \cdot Dc^2}$$

As we know E_p = f (Mm, Dc, tc, Lc, Nc, Ø, Fm, Em, Ec)

E_p = f (Π₁, Π₂, Π₃, Π₄, Π₅, Π₆, Π₇)

Replacing the values of all the Π_1 from above equation and remaining Π values from equation 1-5 we get "Ep" as

$$E_p = \left[\left(\frac{E_p}{Mm Nc^2 Dc^2} \frac{tc}{Dc} \frac{L}{Dc} \quad \emptyset \quad \frac{Fm}{Nc Dc} \frac{Em Dc}{Mm Nc^2} \frac{Ec Dc}{Mm Nc^2} \right) \right]$$

$$E_p = \emptyset \left[\left(\frac{1}{Mm Nc^2 Dc^2} \frac{tc}{Dc} \frac{L}{Dc} \frac{Fm}{Nc Dc} \frac{Em Dc}{Mm Nc^2} \frac{Ec Dc}{Mm Nc^2} \right) \right]$$

Dimensional Equation for Processing Time (tp)

As we know $tp = f(Mm, Dc, tc, Lc, Nc, \emptyset, Fm, Em, Ec)$

$$tp = f(\Pi_1, \Pi_2, \Pi_3, \Pi_4, \Pi_5, \Pi_6, \Pi_7)$$

$$1) \quad \Pi_1 = (Mm)^{a_1}, (Nc)^{b_1}, (Dc)^{c_1}, (tp) \quad \text{----- (13)}$$

$$\Pi_1 = (M)^{a_1}, (T^{-1})^{b_1}, (L)^{c_1}, (T)$$

$$M^0 L^0 T^0 = (M)^{a_1}, (T^{-1})^{b_1}, (L)^{c_1}, (T)$$

Power of M = 0, $0 = a_1$ $a_1 = 0$	Power of L = 0, $0 = c_1$ $c_1 = 0$	Power of T = 0, $0 = -b_1 + 1$ $b_1 = 1$
---	---	--

Putting values of $a_1, b_1,$ and c_1 in equation (13) we get

$$\Pi_1 = Mm^0, Nc^1, Dc^0, tp$$

$\Pi_1 = tp Nc$

As we know $tp = f(Mm, Dc, tc, Lc, Nc, \emptyset, Fm, Em, Ec)$

$$tp = f(\Pi_1, \Pi_2, \Pi_3, \Pi_4, \Pi_5, \Pi_6, \Pi_7)$$

Replacing the values of all the Π_1 from above equation and remaining Π values from equation 1-5 we get "tp" as

$$tp = \left[\left(tp Nc \frac{tc}{Dc} \frac{L}{Dc} \quad \emptyset \quad \frac{Fm}{Nc Dc} \frac{Em Dc}{Mm Nc^2} \frac{Ec Dc}{Mm Nc^2} \right) \right]$$

$$tp = \emptyset \left[\left(tp Nc \frac{tc}{Dc} \frac{L}{Dc} \frac{Fm}{Nc Dc} \frac{Em Dc}{Mm Nc^2} \frac{Ec Dc}{Mm Nc^2} \right) \right]$$

5 Further research methodology to form Experimental

Data based model

Thus in this way the dimensional equations are established in reduced or compact mode in order to make the complete experimentation process less time taking having generation of optimum data.

The experimental data will be generated for formulation of the mathematical model. The experimental set up will be designed which will include the measurement of processing torque, processing time and angular velocity at outlet using specially designed electronic kit, stop

watch and tachometer etc. The extensive experimental data will be generated through experimentations for which the test envelope, test points and plan of experimentation will be decided. The indices of mathematical model will be formulated using regression analysis. The analysis technique implemented for this work will comprise of sensitivity analysis, determination of limiting values, optimization, reliability and AI technique will be used to establish ANN model and to reduce error between experimental and mathematical data. Based on the results conclusions and hypothesis will be made.

The process of this work includes the design of experimentation which comprises of Test Planning, Design of Appropriate Instrument, Physical Design of Experimental Set up, Trial Experimentation, Main Experimentation, Test

Data Checking and Rejection, Formulation of Model, Optimization of Model, Reliability of the Model, Application of AI Techniques for Model Formulation, Comparison of Models, Discussions of Results, Conclusions and hypothesis.

References:

- [1] Moghe S.D., "Formulation of generalized experimental model for determination of optimum cranking arrangement of a cycle rickshaw", proceeding of 10th IFToMM world congress on Theory of machine and mechanism, Union of Oulu- Finland, June 20-24, 1999.
- [2] Modak J. P., "Spealized course on Research Methodology in Engineering", Priyadarshini college of Engineering, Nagpur (India).
- [3] Modak, J. P. and Bapat, A. R., "Formulation of Generalized Experimental Model for a Manually Driven Flywheel Motor and its Optimization", Applied Ergonomics, U.K., Vol. 25, No. 2, pp 119-122, 1994.
- [4] Modak, J. P. and Bapat, A. R, " Manually driven flywheel motor operates wood turning process" Contemporary Ergonomics, Proc. Ergonomics Society Annual Convention 13-16 April, Edinburgh, Scotland, pp 352-357, 1993

- [5] Bapat, A. R., "Design of Experimentation for Establishing Generalized Experimental Model for a Manually Driven Flywheel Motor", Proceedings of International Conference, Modeling and Simulation, New Delhi, Oct. 1987, Vol. 8, pp 127-140.
- [6] Modak, J. P. and Katpatal A.A., "Design of Manually Energized Centrifugal Drum Type Algae Formation Unit" Proceedings International AMSE Conference on System, Analysis, Control and Design, Layon (France), Vol. 3, 4-6 July 1994, pp 227-232.
- [7] C.N. Sakhale et all, "Design and development of a comprehensive bamboo processing machine and estimation of power required for each processing operation" International J. of Engg. Research & Indu. Appls. (IJERIA), Vol.3, No. IV, November 2010, pp. 103-127.
- [8] H. Spenck .Jr, "Theory of engineering experimentation" Mc-GrawHill, inc. Newyork



Mr. V.M. Sonde: Presently he is working as Assistant Professor in Mechanical Engineering Department, Priyadarshini College of Engineering, Nagpur. He is pursuing his Ph.D in Engg. & Tech. from Nagpur University. His specialization is in Mechanical Engg. Design. He has published 5 papers in International Journal and Conferences. He also received Governments funding of Rs. 10.70 Lacs under RPS scheme from AICTE, New Delhi. He is a member of various bodies like AMM, ISTE, ISHRAE.



Mr. S.N. Waghmare: Presently he is working as Assistant Professor in Mechanical Engineering Department, Priyadarshini College of Engineering, Nagpur. He is pursuing his Ph.D in Engg. & Tech. from Nagpur University. His specialization is in Mechanical Engg. Design. He has published 10 papers in International Journal and Conferences. He also received Governments funding of Rs. 10.70 Lacs under RPS scheme from AICTE, New Delhi. He is a member of various bodies like AMM, ISTE, ISHRAE.



Mr. S.K. Undirwade: Presently he is working as Assistant Professor in Mechanical Engineering Department, Priyadarshini College of Engineering, Nagpur. He is pursuing his Ph.D in Engg. & Tech. from Nagpur University. His specialization is in Mechanical Engg. Design. He has published 10 papers in International Journal and Conferences. He also received Governments funding of Rs. 10.70 Lacs under RPS scheme from AICTE, New Delhi. He is a member of various bodies like AMM, ISTE, ISHRAE, IEE.